

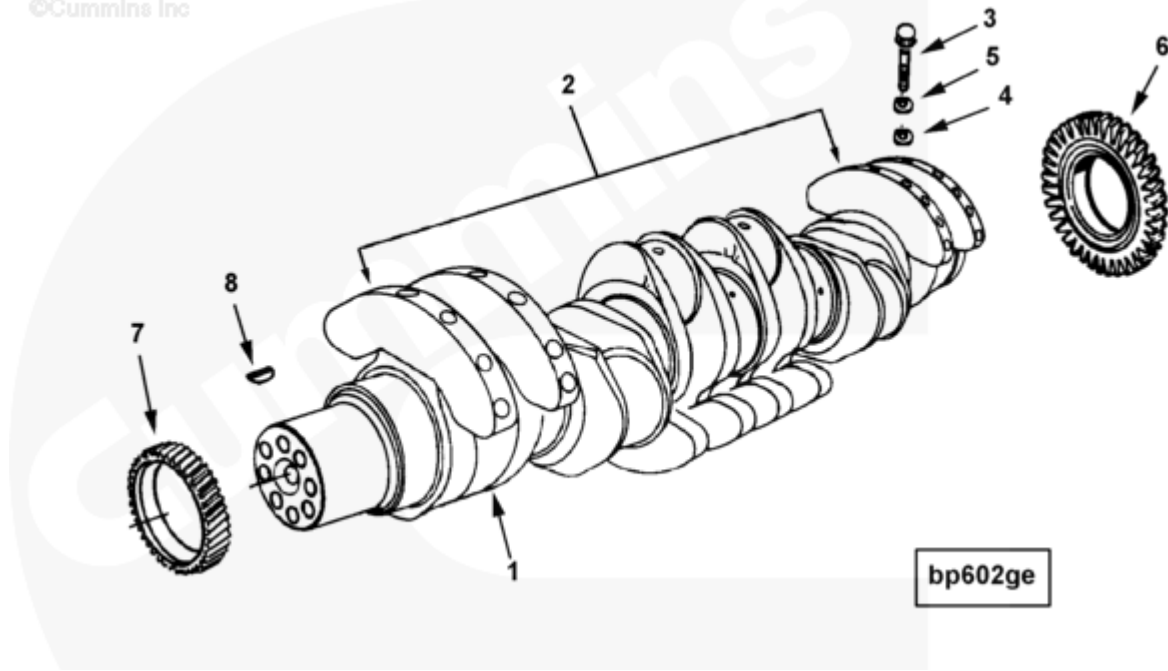

Parts Catalog - Option Detail

Electronic Parts Catalog - Option Detail				
Option	Group	Graphic	Film Card	Date
BP6731-01	01.02	bp602ge	K38	24-JUN-02
Engines	GTA38, K38, KTA38GC CM558, QSK38 CM2150 K106, QSK38 CM2150 MCRS, QSK38 CM850 MCRS			

©Cummins Inc



[SMALL](#) | [MEDIUM](#) | [LARGE](#)

Cart	Ref No	Part Number	Part Description	Required	Remarks
View My Cart					
		BP6731-01	Crankshaft		KT38/KTA38 certified...(More)
					crankshaft assembly with
					3.05in. cranknose bolt circle
					diameter and rolled threads.
					For use when rear gear train
					and rear hydraulic pump
					drives are not specified.
					Has no provision for later
					adaptation.

					For use when marine agency
					approval is specified on m2
					engines only.
<input type="checkbox"/>		3630059	Engine Crankshaft	1	
	1	3630056	Engine Crankshaft	1	
<input type="checkbox"/>	2	3176216	Crankshaft Counter Weight	8	
<input type="checkbox"/>	3	219153	Fracture Resistant Screw	16	
<input type="checkbox"/>	4	3176218	Ring Dowel	16	
<input type="checkbox"/>	5	205126	Plain Washer	16	5/8 in.
<input type="checkbox"/>	6	3175255	Crankshaft Gear	1	
<input type="checkbox"/>	7	3628798	Crankshaft Gear	1	
<input type="checkbox"/>	8	206904	Plain Woodruff Key	1	